

FLEXIBLE IMPELLER PUMPS

ONE SYSTEM - FOUR VERSIONS

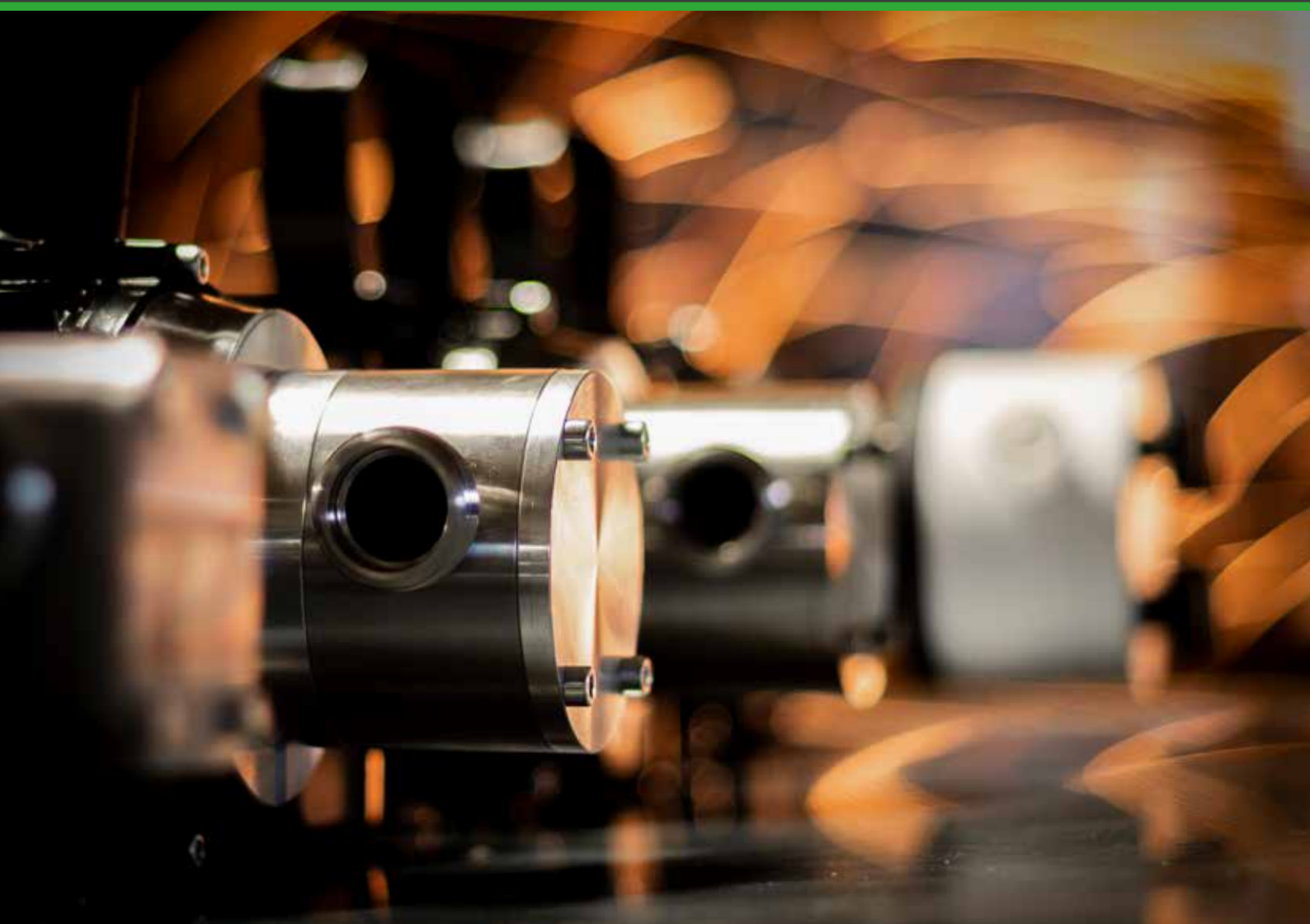

DRY SELF-PRIMING FLEXIBLE IMPELLER PUMP

ZUWA's flexible impeller pumps are very maintenance-friendly and inexpensive to operate. Due to the flexible impellers these pumps are robust against particles in the media and can transfer even highly viscous fluids. Thanks to the different materials of the pump housings, the impellers and drives available, a wide range of different pumps are offered. This modular system makes our impeller pumps suitable for almost any application.

HOW DO FLEXIBLE IMPELLER PUMPS WORK?

The flexible impeller rotates within an eccentrically formed casing creating a suction via the flexing of the impeller blades, which draws the fluid into the pump casing. The medium itself acts as a lubricant between the blades and the casing, therefore minimizing friction and allowing smooth fluid transfer. In order to avoid possible damages to the pump it is recommended to install dry run protection to each flexible impeller pump by ZUWA.

1. SUCTION

On the suction side the blades begin to straighten. The chamber space between each blade enlarges and creates a vacuum pulling the fluid into the pump.

2. TRANSFER

With the turning of the impeller the fluid is positively displaced from the inlet to the outlet. Between the vanes, particles contained in the medium can be transferred.

3. PRESSURE

On the pressure side the blades of the impeller begin to flex and in a constant flow the fluid is forced out of the pump.

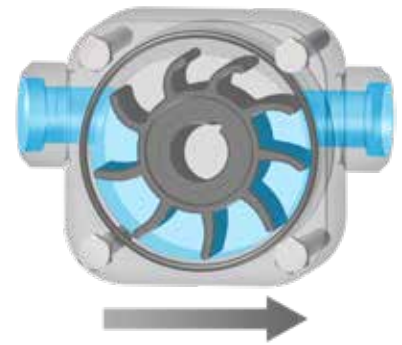
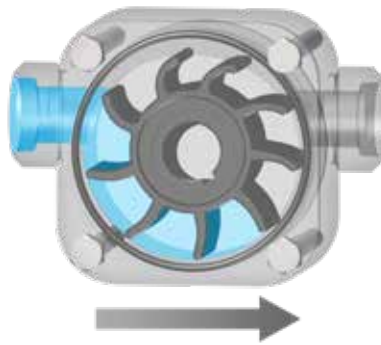
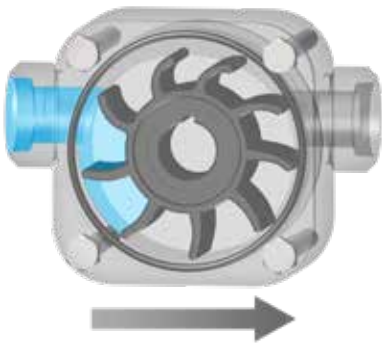

ADVANTAGES OF A FLEXIBLE IMPELLER PUMP

DRY SELF-PRIMING

One of the main advantages of working with a flexible impeller pump is that it is not necessary to fill it prior to operation. The flexible impeller pumps are dry self-priming from a depth of up to three meters. With the suction line filled the maximum suction depth is 7 meters.

HIGH CAPACITY

Depending on type and model our pumps are capable to transfer from 3 up to 730 liters per minute. Containers can be drained down nearly to the last drop.

VERSATILE

Applicable with many different fluids in various applications. The materials of the flexible impellers, seals and pump housings can be selected according to the individual needs and applications required. AC, DC as well as 3-phase motors with varying revolutions per minute are available.

GENTLE

Fluids are transferred without pulsation. Smaller amounts of air can be handled on the suction side.

RELIABLE

All pumps are tested in continuous operation in our workshop. Top quality materials guarantee for a long durability.

EASY MAINTENANCE

The disassembling and assembling of the pump' housing as well as the change of the impeller are easily and quickly done. Replacement parts can be ordered individually. Low operation costs!

STURDY

Impeller pumps transfer fluids with a wide range of viscosity, even highly viscous liquids such as oil or honey (up to 20 000 mPAS) as well as liquids containing solids. The fluids maximum temperature approved is 90 °C. A short dry-run period of up to one minute is tolerated.

UNISTAR

The multi-purpose pump made to transfer clean fluids or fluids a bit soiled. Not suitable for abrasive or corrosive fluids.

NIROSTAR

A high-quality pump made of stainless steel suitable for many different applications in the industry and plant engineering, especially with regard to abrasive and corrosive media.

FIELDS OF APPLICATIONS

- / Maritime applications
- / Bioengineering
- / Heating and sanitation
- / Electro zinc plating and workshops
- / Farming and gardening
- / Water and wastewater treatment
- / Food and beverage industry
- / Industry, mechanical and plant engineering
- / Chemical, pharmaceutical and cosmetics industry

COMBISTAR

The pump suitable for all fluid types also containing abrasives. This type of pump is an economic alternative to the pump version NIROSTAR to transfer abrasive or slightly corrosive media.

ACOSTAR

PTFE flexible impeller pump for the chemical sector. Perfectly suitable for fluids with different viscosities as well as acids, bases, solvents, and various processing media.



Impeller Type A

THE RIGHT IMPELLER MATERIAL FOR EACH APPLICATION



NBR / ACRYLONITRILE-BUTADIENE-RUBBER (PERBUNAN®, BUNA-N®):

For water, antifreeze, heat transfer fluid, mineral and vegetable oil, fats. High impact elasticity and good mechanical strength for applications involving high pressure up to max. 5 bar.



EPDM / ETHYLENE-PROPYLENE-DIENE-RUBBER (KELTAN®, BUNA EP®):

For high temperatures, for acids and bases; high elasticity and very good mechanical stability.



CR / CHLOROPRENE-RUBBER (NEOPRENE®, BAYPRENE®):

Used for applications in the food industry; is flame retardant, tearproof, durable.



FKM OR FPM / FLUOR-RUBBER (VITON®, FLUOREL®):

For diesel, vegetable oils (e.g. palm oil, soybean oil, ...) and mineral oils (e.g. fuel oil, ...), oil-containing wood preservatives, very good chemical resistance, low mechanical strength



PLASTIC / TPU:

For water, mineral and vegetable oils, diesel fuel, heat transfer fluid, antifreeze and several chemicals; extremely tear resistant and a very good mechanical resistance (not suitable for abrasive fluids), maximum fluid temperature 60 °C, not suitable for bi-directional use.

MATERIALS

UNISTAR	2000-A, B AND C	2001-A, B AND C
Pump housing	Aluminum	
Pump cover*	AlMgSi1	
Pump shaft (directly flanged)	NIRO 1.4404 / AISI 316 L	NIRO 1.4404 / AISI 316 L
Pump shaft (with pump carrier)	NIRO 1.4404 / AISI 316 L	✗
Shaft seal	✓	✓
Mechanical seal	optional	✗
Impeller	NBR, EPDM, FKM, CR, TPU	

COMBISTAR	2000-A AND B	2001-A AND B
Pump housing	NIRO 1.4404/AISI 316 L	
Pump cover*	AlMgSi1	
Pump shaft (directly flanged)	NIRO 1.4404 / AISI 316 L	NIRO 1.4404 / AISI 316 L
Pump shaft (with pump carrier)	NIRO 1.4404 / AISI 316 L	✗
Shaft seal	✓	✓
Mechanical seal	optional	✗
Impeller	NBR, EPDM, FKM, CR, TPU	

NIROSTAR	2000-A AND B	2001-A AND B	2000-C	2000-C PLUS	2000-D, E AND F 2001-D, E AND F
Pump housing	NIRO 1.4404/AISI 316 L		NIRO 1.4401 / AISI 316	NIRO 1.4404 / AISI 316 L	NIRO 1.4301 / AISI 304
Pump cover*	NIRO 1.4404/AISI 316 L		NIRO 1.4401 / AISI 316	NIRO 1.4404 / AISI 316 L	NIRO 1.4301 / AISI 304
Pump shaft (directly flanged)	NIRO 1.4404/AISI 316 L		NIRO 1.4301 / AISI 304	NIRO 1.4404 / AISI 316 L	NIRO 1.4301 / AISI 304
Pump shaft (with pump carrier)	NIRO 1.4404 / AISI 316 L	✗	✗	✗	✗
Shaft seal	✓	✓	✗	optional	✗
Mechanical seal	optional	✗	✓	✓	✓
Impeller	NBR, EPDM, FKM, CR, TPU		NBR, EPDM, CR	NBR, EPDM, CR	NBR, EPDM, CR

ACOSTAR	2000-A AND B
Pump housing	PTFE
Pump cover*	PTFE
Pump shaft	NIRO 2.4602 (Hastelloy C22)
Shaft seal	FKM, EPDM
Rod seal	FKM, EPDM
Impeller	FKM, EPDM

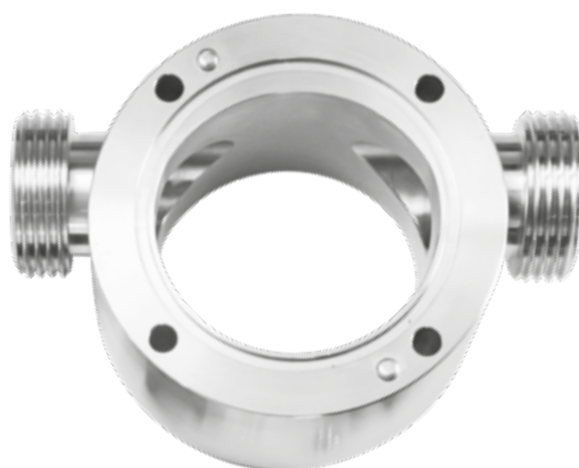

* To protect the aluminium pump covers of the versions UNISTAR and COMBISTAR the impeller is fitted with stainless steel discs (1.4404/AISI 316). The PTFE lids of the ACOSTAR are covered by ceramic discs on the side in touch with the fluid.

ELECTRIC MOTORS

The pump head can either be flanged directly to the motor (compact design) or connected to the motor via pump carrier. Our impeller pumps are available with the following motors and power ratings (and with thermal motor protection for 230 V).

- / 230 V AC single-phase
- / 400 V AC three-phase
- / 12 or 24 V DC
- / Special voltages (110 V, 460 V....)



PUMP CARRIER

With a pump carrier, which is an adapter for pump types A and B, the pump can be mounted on standard motors of size M71 B3/B14. Only 4 screws need to be opened and the pump head can be changed very quickly and easily.



GEAR MOTOR

- / One- or two-stage
- / Continuously variable



HYDRAULIC MOTOR

For connection to the hydraulic port on commercial vehicles



BI-DIRECTIONAL MOTOR

The reversal of the direction of rotation allows you to pump in both directions and thus to empty and re-fill the container without having to reconnect the hoses. The pumps of types A and B can be equipped with a bi-directional motor on request. The pumps of types C to F are all equipped with a bi-directional motor.



PNEUMATIC MOTOR

Handy, extremely light pump type 2001-A with powerful pneumatic motor. Particularly suitable for workshops with available compressed air. Fixation of the pump similar to drill drive with adapter and depth stop.



WITHOUT MOTOR

All ZUWA impeller pumps are also available without drive, thereby allowing the pump head to be equipped to any suitable drive. The drill-driven version allows for this unit to be the ideal service pump.



GEAR BOX FOR V-BELT DRIVE

Gear box with 24 mm stainless steel shaft (NIRO 1.4313) for pulley mounting. The drive shaft is supported by means of double angular contact ball bearings and fixed by the bearing housing. As a result, hardly any axial forces act on the pump shaft and wear is minimized.



DRILL-DRIVEN PUMPS

SMALL, LIGHT, HANDY, AND ALWAYS READY FOR ACTION!

Wherever liquids need to be pumped, the ZUWA drill pump is an unbeatable tool for craftsmen or service technicians and fits into any toolbox. The high-quality stainless steel pump shaft can be clamped in the drill chuck of any standard drill or cordless screwdriver and is thus ready for use in the shortest possible time.

By selecting high-quality and robust materials such as aluminum and stainless steel, a wide variety of areas of application are possible. Be it pumping out manholes, emptying used oil canisters or, for example, refilling solar systems.

The flexible impeller pump is dry self-priming, can pump solids along and is insensitive to air entrapment. It is space-saving, quick to use and very durable.



■ MADE
■ IN
■ GERMANY

TECHNICAL DETAILS

DRILL-DRIVEN PUMP	TYPE A	TYPE B
Flow rate max.	30 l/min	60 l/min
Discharge pressure max.	4 bar	4 bar
Connections	¾"	1"
Minimum drive power	500 W	700 W

UNISTAR 2001-A / 2001-B

Universal pump with aluminum housing for pumping clean fluids or fluids a bit soiled that are not containing abrasive particles e.g., heat transfer medium (glycol), oils, diesel, water, and coolant.

COMBISTAR 2001-A / 2001-B

Pump for abrasive or slightly corrosive liquids, also especially for used oil and waste water. Wetted parts in high quality stainless steel (NIRO 1.4404).

NIROSTAR 2001-A / 2001-B

High quality stainless steel pump (NIRO 1.4404) with many different application possibilities, excellently suitable for corrosive media such as descaling or cleaning agents.



Optional Star Knobs

APPLICATIONS

Due to the use of different types of materials, the the drill pump can be used in a wide variety of areas.

- / Diesel and oil transfer
- / Re-fill solar collectors
- / Drain rainwater barrels
- / Drain aquariums, boats, pools, and ponds
- / Drain or fill water beds

ADVANTAGES

- / Dry self-priming from a depth of up to three meters without the need to pre-fill the pump
- / The flexible impeller also transfers fluids containing particles
- / The pump housings made of aluminum / stainless steel guarantee a long service life
- / The shaft is supported by high quality ball bearings



DRILL ADAPTER

Fitting adapter to connect the pumps to all standard cordless drills or screwdrivers. Simple connection of the pump shaft to the chuck, fixation via depth stop. The assembly takes only two minutes!

Art. no. 11012300

DRILL SUPPORT

With mounting feet the impeller pump is mounted to a regraded support which supports the drill. The adapter and the drill support are separately available to upgrade pumps already at hand.



Art. no. 11012310

UNISTAR 2000-A | 2000-B | 2000-C | 2000 PLUS

The multi-purpose pump made to transfer clean fluids or fluids a bit soiled. Not suitable for abrasive or corrosive fluids.

APPLICATIONS

- / Fill solar collectors
- / Irrigation
- / Use of rain water
- / Domestic water supply
- / Drain flooded basements
- / Fill and refill drums
- / Remove waste oil
- / Wastewater disposal
- / Dispose cooling lubricants
- / Empty water beds
- / Vehicle fueling
- / Car wash
- / Clean tanks
- / Drain tanks

FLUIDS

- / Water, seawater
- / Waste water
- / Diesel fuel, biodiesel
- / Vegetable oils
- / Heating and motor oil
- / Detergents
- / Antifreeze
- / Heat transfer fluid
- / Cooling lubricants



UNISTAR 2000-A



UNISTAR 2000-B



UNISTAR 2000-C

UNISTAR	2000-A								2000-B							
Flow rate max. (l/min.)	15				30				30				60			
Discharge pressure max. (bar)*	4				5				4				5			
Volt	230	400	12	24	230	400	12	24	230	400	12	24	230	400	12	24
rpm	1.400		1.500		2.800		3.000		1.400		1.500		2.800		3.000	
Ampere**	3,2	2,1	21	16	3,2	1,9	28	12	4,4	2,8	30	17	4	2,4	30	17
Engine output	0,37 kW		0,25 kW		0,37 kW		0,25 kW		0,55 kW		0,37 kW		0,55 kW		0,37 kW	
Connections	¾"								1"							
max. temperature	90 °C								90 °C							
Weight	9 kg								9,2 kg							

* with Perbunan impeller

** Increased current values during start-up

CHARACTERISTIC CURVES UNISTAR C

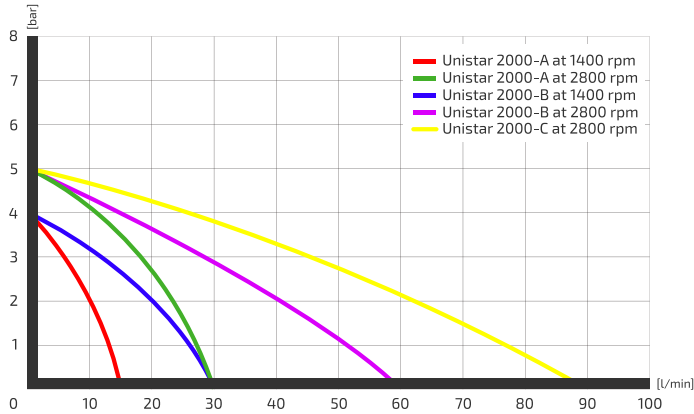

CHARACTERISTIC CURVES UNISTAR C PLUS

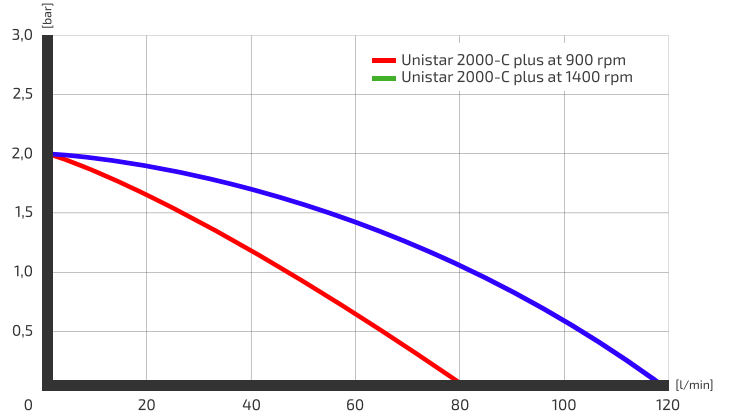

UNISTAR 2000-C PLUS

The PLUS version of the Unistar 2000-C impeller pump is particularly notable for the fact that the pump can be opened without tools. This not only speeds up the cleaning process but also makes it easier to replace the impeller.

FEATURES

- / With clamp closure and locking screw
- / Aluminum pump housing
- / Bi-directional
- / Fluid temperature up to 90 °C
- / Pump head rotatable in 45 ° increments
- / Suitable for continuous operation



UNISTAR 2000-C Plus

UNISTAR	2000 C		2000-C PLUS			
Flow rate max. (l/min.)	90		80		120	
Discharge pressure max. (bar)*	5		2	2	2	
Volt	230	400	230	400	230	400
rpm	2.800		900		1.400	
Ampere**	8,8	2,7	4,4	2,1	6,2	1,75
Engine output	1,1 kW		0,55 kW	0,75 kW	0,9 kW	0,75 kW
Connections	1 ¼"					
max. temperature	90 °C					
Weight	13 kg		17,0 kg	17,7 kg	17,2 kg	17,7 kg

* Bi-directional motor

** Increased current values during start-up

COMBISTAR 2000-A | 2000-B

The pump suitable for all fluid types also containing abrasives. All parts in contact with the medium pumped are made of stainless steel. This type of pump is an economic alternative to the pump version NIROSTAR to transfer abrasive or slightly corrosive media.

APPLICATIONS

- / Clean machines
- / Dispose oil
- / Lime stables
- / Drain tanks
- / Clean canisters
- / Galvanizing baths
- / Remove waste oil
- / Dispose cooling lubricants

FLUIDS

- / Soiled water
- / Grinding emulsions
- / Coolants
- / Lime milk
- / Drilling water
- / Galvanic sludge
- / Soiled oils
- / Cooling lubricants

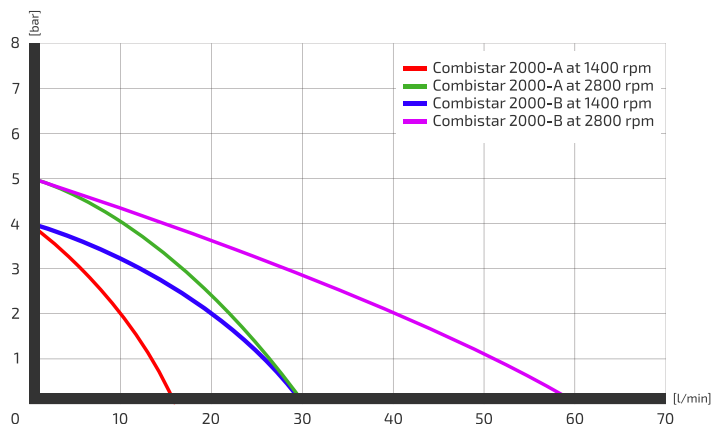

COMBISTAR 2000-B



COMBISTAR 2000-B 12V with pump carrier

COMBISTAR	2000-A								2000-B							
	15		30		30		60									
Flow rate max. (l/min.)	15		30		30		60									
Discharge pressure max. (bar)*	4		5		4		5									
Volt	230	400	12	24	230	400	12	24	230	400	12	24	230	400	12	24
rpm	1.400		1.500		2.800		3.000		1.400		1.500		2.800		3.000	
Ampere**	3,2	2,1	21	16	3,2	1,9	28	12	4,4	2,8	30	17	4	2,4	30	17
Engine output	0,37 kW		0,25 kW		0,37 kW		0,25 kW		0,55 kW		0,37 kW		0,55 kW		0,37 kW	
Connections	¾"								1"							
max. temperature	90 °C								90 °C							
Weight	9,4 kg								10 kg							

* with Perbunan impeller

** Increased current values during start-up



NIROSTAR 2000-A | 2000-B | 2000-C

High-quality stainless steel pumps (also for abrasive and corrosive media) with many application possibilities in industry and plant engineering, frequently used in the food and beverage industry.

APPLICATIONS

- / Filter
- / Transfer
- / Dosing
- / Filling
- / Drain
- / Decalcify
- / Clean

FLUIDS

- / Food, drinks
- / Mash
- / Chemicals
- / Lye
- / Acids
- / Liquid fertilizers
- / Paints
- / Vegetable oils
- / Cooling lubricants
- / Firefighting foam agents
- / Fuel oil, diesel
- / Concrete additives

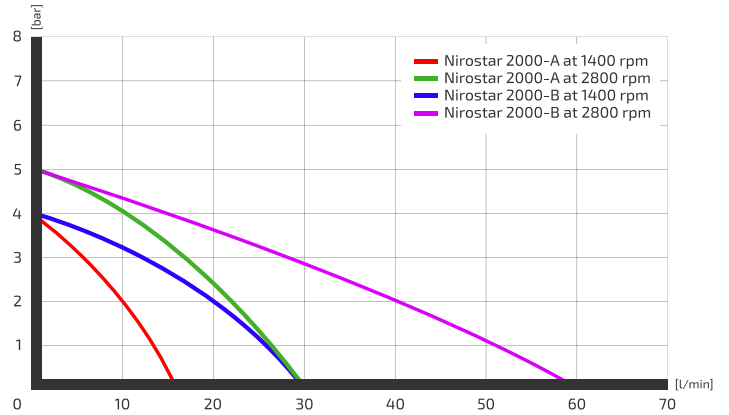

NIROSTAR 2000-B



NIROSTAR 2000-C

NIROSTAR	2000-A								2000-B							
Flow rate max. (l/min.)	15				30				30				60			
Discharge pressure max. (bar)*	4				5				4				5			
Volt	230	400	12	24	230	400	12	24	230	400	12	24	230	400	12	24
rpm	1.400		1.500		2.800		3.000		1.400		1.500		2.800		3.000	
Ampere**	3,2	2,1	21	16	3,2	1,9	28	12	4,4	2,8	30	17	4	2,4	30	17
Engine output	0,37 kW		0,25 kW		0,37 kW		0,25 kW		0,55 kW		0,37 kW		0,55 kW		0,37 kW	
Connections	¾"								1"							
max. temperature	90 °C								90 °C							
Weight	9,8 kg								10,4 kg							

* with Perbunan impeller

** Increased current values during start-up

CHARACTERISTIC CURVES NIROSTAR C

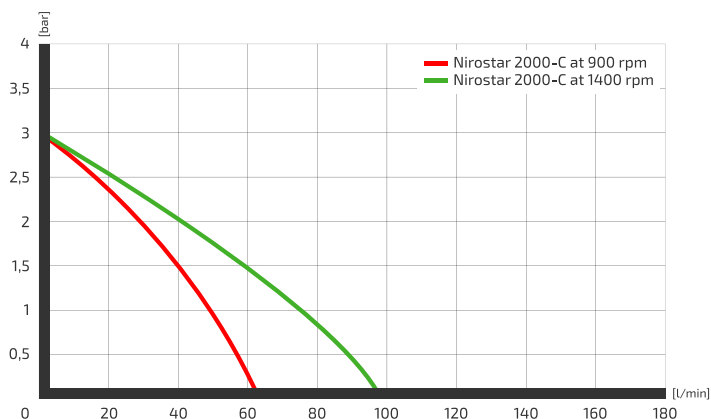

CHARACTERISTIC CURVES NIROSTAR C PLUS

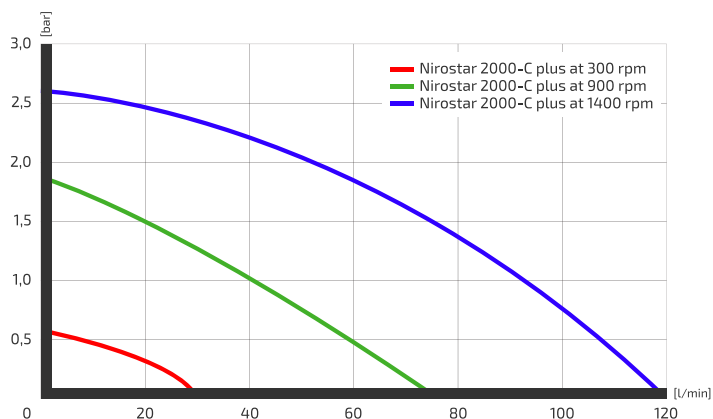

NIROSTAR 2000-C plus

NIROSTAR 2000-C PLUS

The PLUS version of the NIROSTAR 2000-C flexible impeller pump is particularly distinguished by the fact that the pump can be opened without using any tools. This significantly shortens the time needed to clean the pump and to change the impeller.

EQUIPMENT

- / With clip lock and locking screw
- / Pump housing made of stainless steel 1.4404/AISI 316 L
- / Bi-directional
- / Media temperature up to 90 °C
- / Rotate pump head in 45 ° increments
- / Suitable for continuous operation

NIROSTAR	2000-C*				2000-C PLUS			
	230		400		230		400	
Flow rate max. (l/min.)	64		96		80		120	
Discharge pressure max. (bar)*	3		3		2	2	2	
Volt	230		400		230	400	230	400
rpm	900		1400		900		1400	
Ampere**	5	1,7	7,1	2,1	4,4	2,1	6,2	1,75
Engine output	0,56 kW		0,75 kW		0,55 kW	0,75 kW	0,9 kW	0,75 kW
Connections	1 ¼"				1 ¼"			
max. temperature	90 °C				90 °C			
Weight	15 kg				17,0 kg	17,7 kg	17,2 kg	17,7 kg

ALSO AVAILABLE
IN 24 V!

* Bi-directional motor
** Increased current values during start-up

NIROSTAR 2000-D | 2000-E | 2000-F

High-quality stainless steel pumps with high liter capacity (also for abrasive and corrosive media) with many possible applications in industry and plant engineering. Often used in the food and beverage industry.

APPLICATIONS

- / Filter
- / Transfer
- / Dosing
- / Filling
- / Drain
- / Decalcify
- / clean

FLUIDS

- / Food, beverage
- / Mash
- / Chemicals
- / Lye
- / Acids
- / Liquid fertilizers
- / Paints
- / Vegetable oils
- / Cooling lubricants
- / Firefighting foam agents
- / Fuel oil, diesel
- / Concrete additives

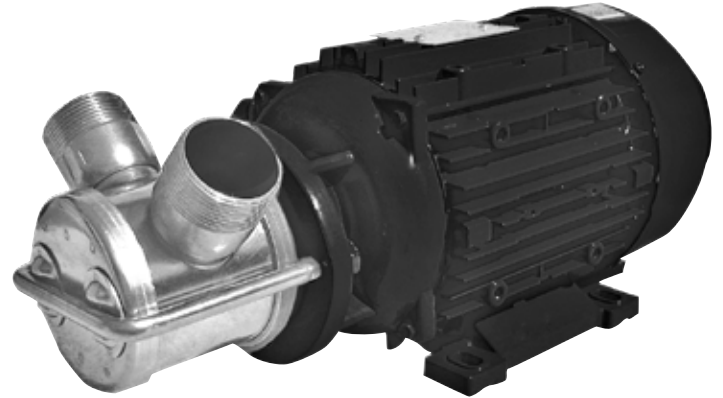

NIROSTAR 2000-D



NIROSTAR 2000-E



NIROSTAR 2000-F with frequency converter and dry-run protection mounted on pump trolley

NIROSTAR	2000-D*			2000-E*		2000-F*	
Flow rate max. (l/min.)	115	115	166	300	375	600	730
Discharge pressure max. (bar)*	3			2		2	
Volt	230	400		400		400	
rpm	900	900	1,400	700	900	470	600
Ampere**	7,9	4,1	3,8	6	5,5	9,5	8,2
Engine output	1,5 kW			1,5 kW	1,87 kW	3,3 kW	3,5 kW
Connections	1½"			2"		3"	
max. temperature	90 °C			90 °C		90 °C	
Weight	20 kg			31 kg	31 kg	69 kg	

* Bi-directional motor

** Increased current values during start-up

CHARACTERISTIC CURVES NIROSTAR D

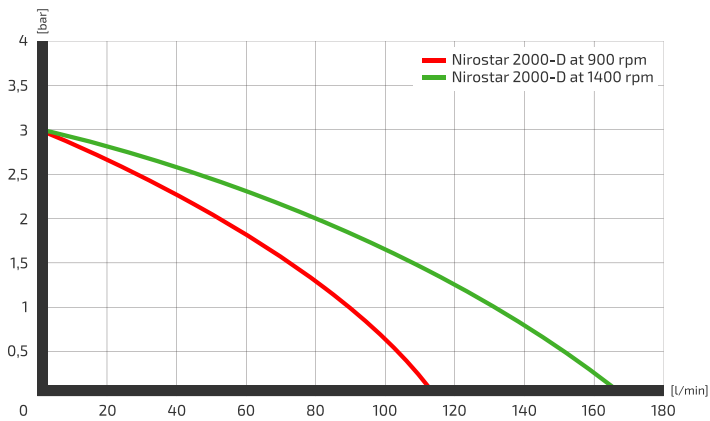

CHARACTERISTIC CURVES NIROSTAR E AND F

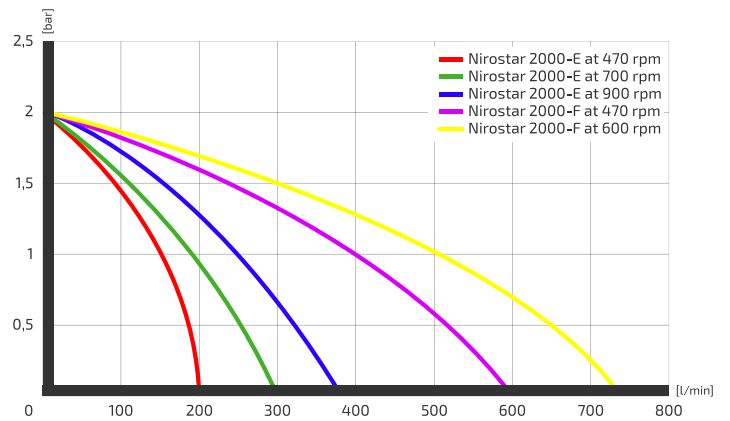

NIROSTAR 2001-D | 2001-E | 2001-F

The Nirostar variants without drive make it possible to implement individual solutions. Particularly where space is limited or a drive is already available, these pumps with their high capacity are ideal for use.



NIROSTAR 2001-D without drive



NIROSTAR 2001-F without drive

NIROSTAR	2001-D	2001-E	2001-F
Flow rate max. (l/min.)	115	375	730
Discharge pressure max. (bar)	3	2	
Volt	NIROSTAR without drive		
rpm			
Ampere			
Engine output			
Connections	1½"	2"	3"
max. temperature	90 °C		
Weight	5,4 kg	9,7 kg	15,7 kg

IMPELLER PUMP MADE OF PTFE FOR THE CHEMICAL SECTOR

The ACOSTAR impeller pump is the optimum pump for the chemical sector thanks to the use of PTFE, high-quality shaft seals and impellers made of FPM/FKM (Viton®) or EPDM. It is suitable for both oxidized, diluted, as well as mixed acids. Dry-running of the pump is prevented by the use of an effective dry-running protector (only for 230/400 V). Various motor versions are available (230 V, 400 V, 12 V, 24 V; 1,400 rpm, 2,800 rpm; 50 Hz, 60 Hz). Using a frequency converter (optional) allows adjustment of the pump's speed and direction of rotation.

The pump shaft of the ACOSTAR is made of Hastelloy® C-22. This material offers good resistance to media such as, sulfuric acid, phosphoric acid, nitric acid, chlorine gas, acid mixtures containing sulfuric acid, and oxidizing acids containing chloride ions. In the presence of strong oxidizing agents such as iron(III) and copper(II) chlorides, chlor, formic acid, acetic acid, seawater and other salt solutions, the use of this material is recommended after clarification of the environmental conditions. A special feature of this alloy is its high resistance to crevice, pitting and stress corrosion cracking at elevated temperatures under oxidizing and reducing conditions.

Star handles for quick and easy impeller replacement and ceramic side discs to protect the pump covers are installed as standard. The newly developed bellhousing allows the pump to be easily separated from the motor to perform service work.



ACOSTAR without drive

MADE
 IN
 GERMANY

PART	MATERIAL
Pump housing	PTFE
Pump cover*	PTFE
Pump shaft	Hastelloy® C-22, material number 2.4602
Shaft seal	FKM, EPDM
Rod seal	FKM, EPDM
Impeller	FKM, EPDM

* The PTFE lids of the ACOSTAR are covered and protected by ceramic discs on the side in touch with the fluid.

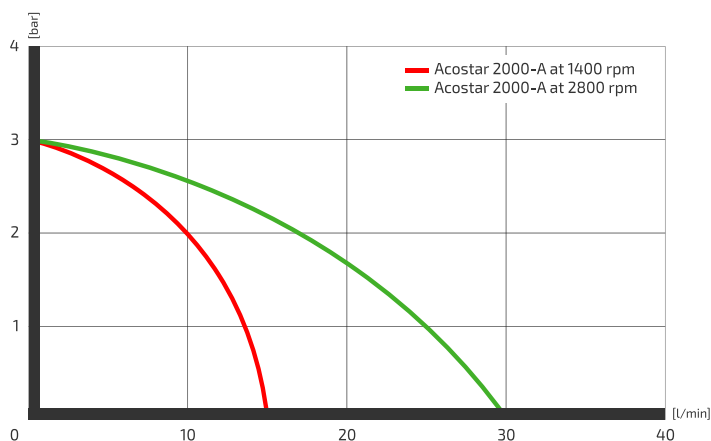

ACOSTAR 2000-A

- / Dry self-priming flexible impeller pumps
- / Made of PTFE (TEFLON®)
- / Suitable for corrosive media
- / Up to 3 meters dry priming
- / Head up to max. 30 meters
- / Flow rate between 3 and 28 l/min
- / Dry run protection as standard

ACOSTAR WITH FREQUENCY CONVERTER

By using a frequency converter the speed can be regulated continuously and the desired flow rate can be adjusted precisely during filling and dosing. Energy efficiency through adapted engine performance.

- / Speed regulation
- / Reversal of the direction of rotation
- / Overload protection
- / Precise drive control
- / Compact design
- / High energy efficiency



Connection $\frac{3}{4}$ " male thread



Connection spout $\frac{3}{4}$ "



CONNECTIONS

You can choose between a $\frac{3}{4}$ " male thread connection or a $\frac{3}{4}$ " connection spout. Both connections are made of robust PTFE.

ACOSTAR	2000-A			
	1400 rpm		2800 rpm	
Flow rate max. (l/min.)	14		28	
Discharge pressure max. (bar)	3			
Volt	230	400	230	400
rpm	1400		2800	
Ampere**	3,2	2	3,2	1,9
Engine output	0,37 kW			
Connections	$\frac{3}{4}$ " male thread or Connection spout $\frac{3}{4}$ "			
Temperature (with dry run protection)	90 °C			
Weight	9,4 kg			

** Increased current values during start-up

FREQUENCY CONVERTER

INTELLIGENT CONTROL OF IMPELLER PUMPS

By using a frequency converter the speed can be regulated continuously and the desired flow rate can be adjusted precisely during filling and dosing. In addition, high energy efficiency results from adapted engine power.

ADVANTAGES:

- / Reversal of the direction of rotation
- / Overload protection
- / Precise drive control
- / Compact design
- / High energy efficiency
- / Continuously adjustable
- / Freely configurable PID controller

SOFTWARE FEATURES:

- / Process control (PID controller)
- / Fixed frequencies
- / Data record switchover
- / Catch function
- / Motor current limit

PROTECTIVE FUNCTIONS:

- / Over- and undervoltage
- / I2t limit
- / Short circuit / ground fault
- / Motor and drive controller temperature
- / Anti-tilt
- / Blocking recognition
- / PID dry-run protection



Nirostar 2000-B with INVEOR alpha



OPTIONALLY WITH BLUETOOTH CONTROL

Control your impeller pump conveniently from your smartphone or tablet. Store, load, and send motor data sets and monitor your pumps wirelessly in live operation.

- / Easy commissioning via app
- / Clear fault analysis
- / 100 % compatible to PC software

ARTICLE	VOLTAGE	NOMINAL CURRENT	RECOMMENDED FOR	ARTICLE NUMBER
Motor-mounted frequency converter INVEOR alpha	230 V	6,9 A	0,37 kW to 0,75 kW	170010
Motor-mounted frequency converter INVEOR MA 1,1	230 V	9,2 A	0,75 kW to 1,1 kW	17001020
Motor-mounted frequency converter INVEOR MP BG B 2,2	400 V	4,6 A	1,2 kW to 2,2 kW	170010211
Motor-mounted frequency converter INVEOR MP SZ B 3,0	400 V	6,2 A	2,3 kW to 3,00 kW	17001023
Interface line INVEOR	Connection from PC to motor-mounted frequency converter			170016
Bluetooth stick	Suitable for frequency converter INVEOR			17001060

Other versions as well as frequency converters for wall mounting available on request!

CHARACTERISTIC CURVES OF PUMPS WITH FREQUENCY CONVERTER

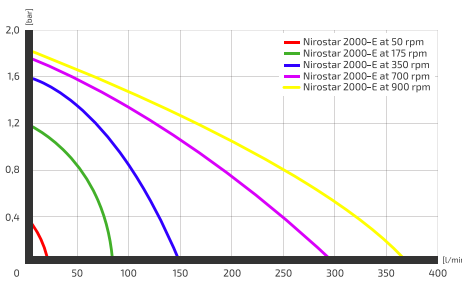
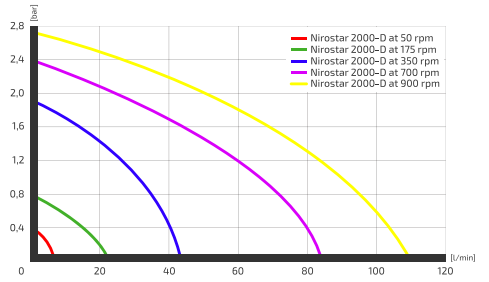
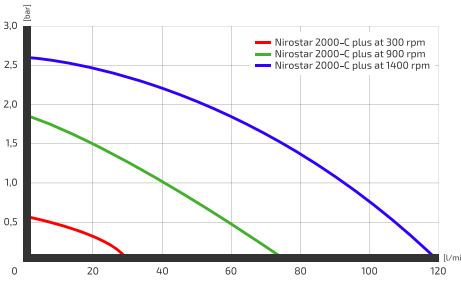
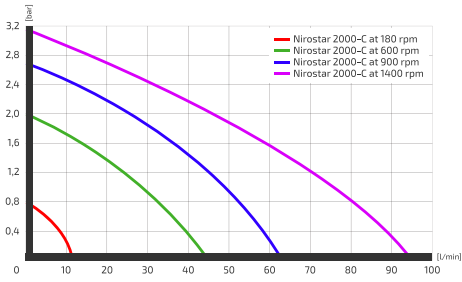
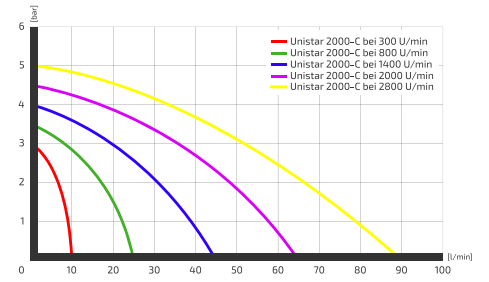
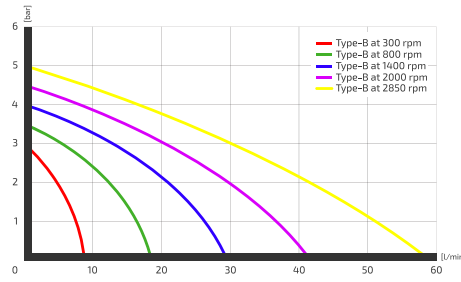
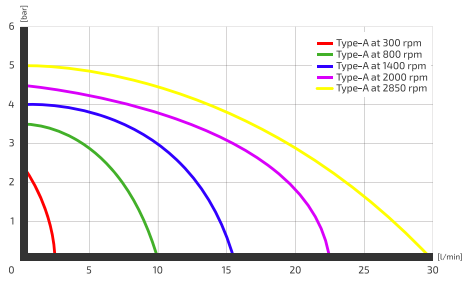

Nirostar 2000-D with INVEOR MP 2.2



Nirostar 2000-E with INVEOR MP 3.0

THE WORLD'S FIRST IMPELLER PUMP FOR USE IN POTENTIALLY EXPLOSIVE ATMOSPHERES

WHAT IS ATEX?

ATEX is an abbreviation for „**AT**mosphere **EX**plosible“. At the same time, ATEX is the abbreviated name of the European Directive 2014/34/EU concerning the placing on the market of explosion-proof electrical and mechanical equipment, components and protective systems. It has applied to all new equipment and protective devices since July 1, 2003.

APPROVAL FOR USE IN POTENTIALLY EXPLOSIVE ATMOSPHERES

The ATEX-NIROSTAR series has a type examination by a notified body in accordance with Annex III of Directive 2014/34/EU, including the essential health and safety requirements in accordance with Annex II of Directive 2014/34/EU as a category 2 non-electrical device.

Type Examination Certificate No.: **BVS 18 ATEX H 004 X**

EQUIPMENT LABEL AND CLARIFICATION:

EX II2/2G¹ EX² IIB³ T2⁴ GB/GB⁵ +5 °C ≤ TA ≤ +40 °C

1. Equipment Group II – Surface Industries, Equipment Category 2 Gas / Vapor G, Suitable for Zone 1 and 2
2. Type of protection for non-electrical equipment in potentially explosive atmospheres. Explosion protection in accordance to ISO 80079-36/37 Standards. Type of protection “Constructional Safety“- Marked with EX
3. Gas Group IIB
4. Temperature Class T2 (Gas) Maximum Surface Temperature 300 °C
5. Explosion Protection Level Gb (High Level of Protection) Gas

Labeling according to RL 2014/34/EU and ISO 80079 Part 36

The **NIROSTAR ATEX** is the first flexible impeller pump in the world with ATEX approval. The pump unit and electronic controls are mounted together on a sturdy trolley with large solid rubber tires (electrically conductive). The trolley includes a height-adjustable telescopic handle to ensure easy mobility in and around the worksite. Due to the compact design of the NIROSTAR ATEX, it is transportable in most passenger cars.

The **NIROSTAR ATEX** brings all the advantages of a high quality flexible impeller pump including dry self-priming, suitability for abrasive and corrosive liquids, and pulsation-free flow.



	NIROSTAR 2000-A	NIROSTAR 2000-B
Capacity	max. 30 l/min	max. 60 l/min
Discharge pressure	max. 5 bar	max. 5 bar
Inlet / Outlet connections	¾"	1"
rpm	max. 2.800 U/min	max. 2.800 U/min
fluid temperature	max. 60 °C	max. 60 °C
Pump head	max. 7 meters (dry max. 3 meters)	max. 7 meters (dry max. 3 meters)
Weight	46,5 kg	47 kg

MOBILE IMPELLER PUMP WITH PLATE FOR FAST AND SECURE MOUNTING ON DRUM

FEATURES:

- / Dry self-priming flexible impeller pumps
- / Pump casings aluminium or stainless steel
- / Impeller materials NBR or Viton
- / The AC and DC motors are suited for continuous operation
- / Drum bracket available for drums up to 380 mm and 580 mm
- / Including a manual nozzle and nozzle holder



MOBILE IMPELLER PUMP WITH PLATE FOR MOUNTING ON IBC-CONTAINER

FEATURES:

- / Dry self-priming flexible impeller pumps
- / Pump casings aluminium or stainless steel
- / Impeller materials NBR or Viton
- / The AC and DC motors are suited for continuous operation
- / Including a manual nozzle and nozzle holder
- / 3.5 meters hose with spiral liner

DRUM PUMPS	HOUSING	MOTOR	FLOW RATE MAX.	DRUM SIZE	IMPELLER	ART. NO.
NIRO 380-A	Stainless steel	230 V	30 l/min	340 to 380 mm	Viton	120717
NIRO 380-B	Stainless steel	12/24 V	12/25 l/min	340 to 380 mm	Viton	120718
UNI 380-A	Aluminum	230 V	30 l/min	340 to 380 mm	NBR	120719
UNI 380-B	Aluminum	12/24 V	12/25 l/min	340 to 380 mm	NBR	120720
NIRO 580-B	Stainless steel	230 V	60 l/min	540 to 580 mm	Viton	120721
NIRO 580-B	Stainless steel	12/24 V	12/25 l/min	540 to 580 mm	Viton	120722
UNI 580-B	Aluminum	230 V	60 l/min	540 to 580 mm	NBR	120723
UNI 580-B	Aluminum	12/24 V	12/25 l/min	540 to 580 mm	NBR	120724

IBC PUMP SET	HOUSING	MOTOR	FLOW RATE MAX.	DRUM SIZE	IMPELLER	ART. NO.
NIROSTAR-A	Stainless steel	230 V	30 l/min	✗	Viton	120730
NIROSTAR-B	Stainless steel	230 V	60 l/min	✗	Viton	120731
UNISTAR-A	Aluminum	230 V	30 l/min	✗	NBR	120732
UNISTAR-B	Aluminum	230 V	60 l/min	✗	NBR	120733

ACCESSORIES

DRY-RUN PROTECTION

A dry run protection can be added to the impeller pumps. To protect the flexible impeller from overheating, a sensor interrupts the power supply. Flexible impeller pumps already on hand can easily be upgraded with a dry run protection.



STAR HANDLES

Allow the pump to be opened without tools. The pump can be cleaned or serviced quickly and easily without having to remove it from a pipeline. (for NIROSTAR A and B)



CARRIER

Carrying frame for convenient transport for all impeller pumps of the 2000 series (except NIROSTAR 2000-E and NIROSTAR 2000-F).



TOOL FOR IMPELLER REPLACEMENT

Aid for inserting the impeller into the housing, suitable for all ZUWA impeller pumps of the type A and B.



FLOW REGULATOR

With a flow regulator, also known as setter, the flow rate can be set to a certain, predefined flow rate. A meter is integrated into the housing.

- / Flow rate range: 8-30 l/min or 10-40 l/min
- / Connection thread: 2x1" mt
- / Working pressure max.: 10 bar
- / Material: brass (approved for drinking water)



PRESSURE SWITCH

The pressure switch stops the pump when it reaches a predefined pressure. As soon as the pressure drops by 30 % the pump starts up automatically again (only for 400 V pumps).

- / Shift pressure: definable from 1-10 bar
- / Material: stainless steel or brass



REMOTE CONTROLS

FOR FREQUENCY CONVERTERS

Remote control with 15m cable for controlling the speed and running direction of the frequency inverter. (for model NIROSTAR from size C)

PUMP REMOTE CONTROL

10 meter extension cord with on/off switch.

RADIO REMOTE CONTROL

Small transmitter with receiver.



NIROSTAR 2000-C with frequency converter and remote control



Radio remote control



Pump remote control

METERS

Electronic and mechanical meters for a wide variety of fluids and applications.



TRANSPORT TROLLEY

Cart with detachable handle and practical cable holder.





ZUWA-Zumpe GmbH
Franz-Fuchs-Str. 13 - 17
83410 Laufen
Germany
Tel.: +49 (0) 8682 8934-50
E-Mail: export@zuwa.de
Web: www.zuwa.de/en

